

MATHEMATICS

11. Babloo ranked 16th from the top and 29th from the bottom among those who passed an examination, 6 boys did not participate in the competition and 5 failed in the examination. How many boys were there in that class?

- (1) 44 (2) 50
(3) 55 (4) 40

12. Which of the following is non terminating?

- (1) $\frac{13}{3125}$ (2) $\frac{17}{8}$
(3) $\frac{64}{455}$ (4) $\frac{29}{343}$

13. Solve for x in $x + \left(\frac{21}{x}\right) = -10$

- (1) -7 (2) 10
(3) -21 (4) 21

14. Find the zeroes of the quadratic polynomial $x^2 + 7x + 12$.

- (1) -2, -5
(2) 2, 5
(3) -3, -4
(4) 3, 4

15. The price of the commodity X increases by 40 paise every year, while the price of the commodity Y increases by 15 paise every year. If in 2014 the price of commodity X was ₹4.20 and that of Y was ₹6.30, in which year commodity X will cost 40 paise more than the commodity Y?

- (1) 2024
(2) 2021
(3) 2022
(4) 2023

16. The coordinates of the point which is equidistant from the three vertices of the ΔAOB as shown in the figure is:

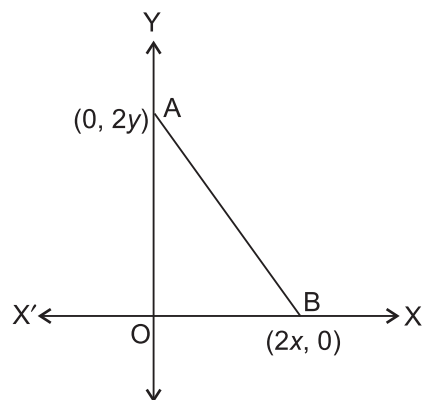

- (1) (x, y) (2) (y, x)
(3) $(x/2, y/2)$ (4) $(y/2, x/2)$

17. In the right triangle shown here, $AB + AD = BC + CD$, if $AS = x$ and $CD = d$, then x is equal to

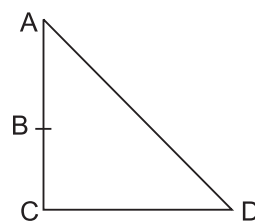

- (1) $d - h$ (2) $hd/(2h + d)$
(3) $h + d$ (4) $h/2$

18. Volume and surface area of a solid hemisphere are numerically equal. What is the diameter of hemisphere?

- (1) 3 cm (2) 5 cm
(3) 8 cm (4) 6 cm

19. The mean height of the 10 girls of a class is 1.4 m and the mean height of the 30 boys of the class is 1.45 m. Find the approximate mean height of the 40 students of the class.

- (1) 1.39 m (2) 1.46 m
(3) 1.42 m (4) 1.44 m

20. A number is chosen at random from the number -3, -2, -1, 0, 1, 2, 3. What will be the probability that square of this number is less than or equal to 1?

- (1) $4/7$ (2) $2/3$
(3) $3/7$ (4) $1/7$

21. If $4 \cos \theta = 11 \sin \theta$, find the value of $\frac{11 \cos \theta - 7 \sin \theta}{11 \cos \theta + 7 \sin \theta}$.
- (1) $\frac{93}{149}$ (2) $\frac{149}{93}$
 (3) $\frac{121}{28}$ (4) $\frac{7}{28}$
22. At a farm, there are hens, cows, bullocks and keepers to look after them. There are 69 heads less than legs. The number of cows is double than that of the bullocks but the number of the cows and hens is the same. There is one keeper per 10 birds and cattle. The total number of hens plus cows and bullocks and their keepers does not exceed 50. How many cows are there?
- (1) 16 (2) 10
 (3) 14 (4) 12
23. An equilateral triangle is inscribed in a circle of the circumference equal to perimeter of a square with side 22 cm. Find its side?
- (1) 17 cm (2) $14\sqrt{3}$ cm
 (3) 14 cm (4) $7\sqrt{3}$ cm
24. Which of the following is not a rational number?
- (1) $\sqrt{4}$ (2) $3\sqrt{18}$
 (3) $\sqrt{1.44}$ (4) $-\sqrt{64}$
25. If $x = -\frac{1}{2}$, is a solution of the quadratic equation $3x^2 + 2kx - 3 = 0$, find the value of k .
- (1) $\frac{7}{4}$ (2) $-\frac{7}{4}$
 (3) $-\frac{9}{4}$ (4) $\frac{9}{4}$
26. The difference between two numbers is 26 and one number is three times the other. Find x .
- (1) 13 (2) 39
 (3) 15 (4) $\frac{26}{7}$
27. How many two digit numbers is divisible by 3 are: 12, 15, 18,, 99
- (1) 29 (2) 39
 (3) 35 (4) 30
28. The distance between the points (0, 5) and (-5, 0) is:
- (1) 5 (2) $5\sqrt{2}$
 (3) $2\sqrt{5}$ (4) 10
29. Find the value of p for which the roots of the equation $px(x - 2) + 6 = 0$ are equal.
- (1) 5 (2) 6
 (3) 8 (4) 4
30. How many lead shots each 3 mm in diameter can be made from the cuboid of the dimension 9 cm \times 11 cm \times 12 cm?
- (1) 7200 (2) 8400
 (3) 72000 (4) 84000
31. The following number of goals was scored by a team in a series of 10 matches: 2, 3, 4, 5, 0, 1, 3, 3, 4, 3. Find the mean, median and mode of the scores.
- (1) 2.8, 3, 3 (2) 3, 3, 3
 (3) 3.2, 1, 5 (4) 2.8, 1, 3
32. A piggy bank contains hundred 50 p coins, fifty ₹1 coins, twenty ₹2 coins and 10 ₹5 coins. If it is equally likely that one of the coins will fall out when the piggy bank is turned upside down, find the probability that the coin will not be 50 p coin.
- (1) $\frac{1}{8}$ (2) $\frac{4}{9}$
 (3) $\frac{1}{18}$ (4) $\frac{2}{9}$
33. Evaluate: $\left(\frac{\sin 27^\circ}{\cos 63^\circ}\right)^2 + \left(\frac{\cos 63^\circ}{\sin 27^\circ}\right)^2$.
- (1) 0.5 (2) 4
 (3) 2 (4) 1
34. Using factorization, find the roots of the quadratic equation: $3x^2 + 10 = 11x$
- (1) $\frac{5}{4}$ (2) 4
 (3) 1 (4) 2
35. AOBC is a rectangle whose three vertices are A(0, 3), O(0, 0) and B(5, 0). The length of its diagonal is:
- (1) 5 (2) 3
 (3) $\sqrt{34}$ (4) 4

36. In what ratio must rice at ₹7.20 per kg be mixed with rice at ₹5.70 per kg so that the mixture be worth ₹6.30 per kg
- 1:3
 - 2:3
 - 3:4
 - 4:5
37. Use Euclid's division algorithm to find HCF of 135 and 225
- 30
 - 45
 - 35
 - 40
38. The sum of the digits of two digit number is 9. Also, nine times this number is twice the number obtained by reversing the order of the digits.
- 17
 - 27
 - 28
 - 18
39. One root of the quadratic equation $2x^2 - x - \frac{1}{8} = 0$ is $\frac{1}{4}$. The other root is _____
- $\frac{1}{4}$
 - 0
 - $\frac{1}{8}$
 - $-\frac{1}{4}$
40. Find the sum of the following AP: 2, 7, 12, upto 10 terms
- 230
 - 245
 - 235
 - 240

INTERACTIVE SECTION

41. Find the ratio in which the joining of points $(-3, 10)$ and $(6, -8)$ is divided by the point $(-1, 6)$.
- 2:7
 - 3:7
 - 4:7
 - 1:5
42. A towel, when bleached, was found to have lost 20 % of its length and 10% of its breadth. The percentage of decrease in the area is _____.
- 10%
 - 10.08%
 - 20%
 - 28%
43. If the 45th element of an arithmetic progression is 329 and the 30th element is 224, then what is the 11th element?
- 99
 - 91
 - 89
 - 98
44. If we add 1 to the numerator and subtract 1 from the denominator, a fraction reduces to 1. It becomes $\frac{1}{2}$ if we only add 1 to the denominator. What is the fraction?
- $\frac{4}{5}$
 - $\frac{3}{5}$
 - $\frac{2}{5}$
 - $\frac{2}{3}$
45. Find the median from the following data.
- | | | | | | | |
|-------|---|---|---|---|---|----|
| x_i | 5 | 6 | 7 | 8 | 9 | 10 |
| f_i | 4 | 5 | 7 | 9 | 7 | 6 |
- 9
 - 10
 - 7
 - 8

46. $\sin 4A = \cos (A - 20^\circ)$, where $4A$ is an acute angle, find the value of A .
- (1) 22°
 (2) 25°
 (3) 35°
 (4) 60°
47. Two concentric circles with radii 10 cm and 6 cm are given. The length of the chord MB which touches the inner circle is
- (1) 18 cm
 (2) 6 cm
 (3) 16 cm
 (4) 8 cm
48. A bag contains 12 green balls and some red balls. If the probability of drawing a red ball is half that of a green ball, then the number of red ball in the bag is?
- (1) 18
 (2) 6
 (3) 16
 (4) 8
49. A metallic sphere of radius 4.5 cm is melted and recast into the shape of a cylinder of radius 4 cm. The height of the cylinder is
- (1) 8 cm
 (2) 7.6 cm
 (3) 7.8 cm
 (4) 8.2 cm
50. Instead of walking along two adjacent sides of a rectangular field, a boy took a short cut along the diagonal of the field and saved a distance equal to $\frac{1}{2}$ of the longer side. Then the ratio of the shorter side of the rectangle to the longer side is _____.

- (1) $\frac{1}{2}$
 (2) $\frac{5}{7}$
 (3) $\frac{4}{3}$
 (4) $\frac{3}{4}$

51. A string of the length $50\sqrt{3}$ attached to a kite is temporarily tied to a point on the ground at an inclination α° string Find the angle of inclination of the string if the kite is flying at a height of 75 m above the ground, assuming that there is no slack in the string.

- (1) 30° (2) 60°
 (3) 45° (4) 90°

52. Five year ago, Nuri was thrice as old as Sonu. Ten years later, Nuri will be thrice as old as Sonu. How old is Nuri?

- (1) 18 (2) 20
 (3) 40 (4) 50

53. The following distribution shows the daily pocket allowance of children of a locality. The mean pocket allowance is ₹18. Find the missing frequency f .

Daily pocket allowance (in ₹)	Number of workers
11–13	7
13–15	6
15–17	9
17–19	13
19–21	f
21–23	5
23–25	4

- (1) 18
 (2) 19
 (3) 20
 (4) 17

54. In the figure, from a cuboidal solid metallic block, of dimension $15\text{ cm} \times 10\text{ cm} \times 5\text{ cm}$, a cylindrical hole of diameter 7 cm is drilled out. Find the surface area of the remaining block.

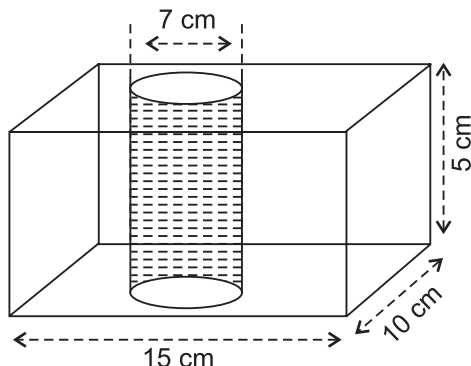

- (1) 583 cm^2
 (2) 685 cm^2
 (3) 473 cm^2
 (4) 627 cm^2
55. A forester wants to plant 66 apple, 88 banana trees and 110 mango trees in equal rows (in terms of the number of trees). Also he wants to make distinct rows of trees (i.e., only one type of tree in one row). The number of minimum rows required are _____.
- (1) 2
 (2) 3
 (3) 10
 (4) 12
56. From the well shuffled pack of 52 cards few cards of the same colour are missing. If the probability of picking a card is $P(\text{Red card}) = \frac{2}{3}$ and $P(\text{Black card}) = \frac{1}{3}$, then which colour of cards are missing and how many?
- (1) 12 red cards
 (2) 13 black cards
 (3) 12 black cards
 (4) 13 red cards
57. A van has two wipers which have a blade of length 25 cm sweeping through an angle of 110° . Find the total area cleaned at each sweep of the blades if the wipers do not overlap at all.

- (1) 1200 cm^2
 (2) 600 cm^2
 (3) 800 cm^2
 (4) 900 cm^2

58. A solid wooden toy is in the form of a hemisphere surmounted by a cone of the same radius. The radius of the hemisphere is 3.5 cm and the total wood used in the making of the toy is $166\left(\frac{5}{6}\right)\text{ cm}^3$. Find the height of the toy.

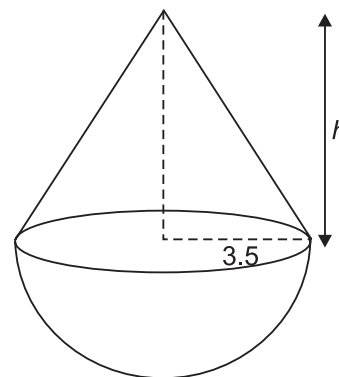

- (1) 6 cm
 (2) 8.5 cm
 (3) 9.5 cm
 (4) 9 cm
59. Half the perimeter of a rectangular garden, whose length is 4 m more than its width, is 36 m . Find the dimensions of the garden.
- (1) $14\text{ cm}, 18\text{ cm}$
 (2) $16\text{ cm}, 20\text{ cm}$
 (3) $15\text{ cm}, 19\text{ cm}$
 (4) $18\text{ cm}, 22\text{ cm}$
60. Two poles of equal height are on either side of a road, which is 200 m wide. The angles of the top of the pillars are 60° and 30° at a road between the pillars. Find the position of the point between the pillars and the height of each pillar.
- (1) 50 m
 (2) 60 m
 (3) 55 m
 (4) 65 m



END OF THE EXAM