

4. Choose from the alternatives, the box that will be formed when the given figure is folded?

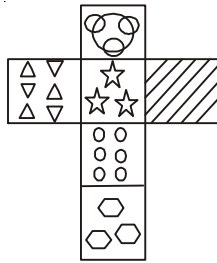

- (1) (2) (3) (4) None of these

5. Take 1000 and add 40 to it. Now add another 1000. Now add 30. Add another 1000. Now add 20. Add another 1000. Now add 10. What is the total?

- (1) 5000 (2) 4100
(3) 5100 (4) None of these

6. Find the picture that follows logically from the diagrams to the right?

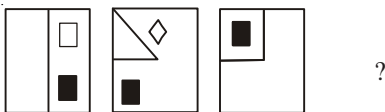

- (1) (2) (3) (4) None of these

7. Which of the following number comes next in the given series?

7, 11, 19, 35, ___ ?

- (1) 67 (2) 68
(3) 69 (4) None of these

8. Identify the figure that completes the pattern in X

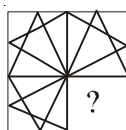

(X)

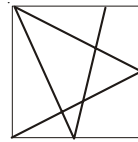

(A)

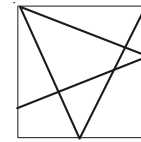

(B)

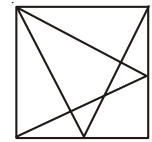

(C)

- (1) A (2) B
(3) C (4) None of these

9. If New York can be encrypted as PGYAQTM, how can you code the word CHARLOTTE ?

- (1) EICSNPVVG (2) EICTNQVVG
(3) EJCSMPVVG (4) None of these

10. How many are in ?

- (1) 6 (2) 8
(3) 4 (4) None of these

SECTION-B : PHYSICS & CHEMISTRY

11. Which type of mirrors are fitted on the sides of the vehicle enabling the driver to see the traffic behind him to facilitate safe driving?

- (1) Convex mirror (2) Concave mirror
(3) Plane mirror (4) None of these

12. Which of the following bases can be used as an antacid ?

- (1) Baking soda (2) Milk of magnesia
(3) Washing soda (4) None of these

13. Which of the following statement is true?

- (1) The magnetic field produced by a given current in the conductor decreases as the distance from it increases.
(2) The magnetic field produced by a given current in the conductor increases as the distance from it decreases.
(3) The magnetic field produced by a given current in the conductor remains constant as the distance from it increases.
(4) None of these

14. Ionic compounds in the solid state do not conduct electricity where as in the molten state can conduct. This is because

- (1) Ionic compounds in the solid state are brittle and hence do not conduct electricity where as in the molten state the ions move to the opposite electrodes thereby conducting electricity.
(2) Ionic compounds in the solid state have high melting and boiling points and there by do not conduct electricity where as in the molten state the melting and boiling points are low and hence they conduct electricity.
(3) Ionic compounds in the solid state do not conduct electricity because movement of ions in the solid is not possible due to their rigid structure but in the molten state the electrostatic forces of attraction between the oppositely charged ions are overcome due to heat, thus ions move freely and conduct electricity.
(4) None of these

15. Silver articles become black after sometime when exposed to air. This is because
- (1) Silver reacts with oxygen in the air to form a coating of silver oxide.
 - (2) Silver reacts with sulphur in the air to form a coating of silver sulphide.
 - (3) Silver when exposed to moist air for a long time acquires a coating of a brown flaky substance called rust.
 - (4) None of these
16. An electric bulb is connected to a 220V generator. The current is 0.50 A. What is the power of the bulb ?
- (1) 110W
 - (2) 120W
 - (3) 125W
 - (4) None of these
17. A current through a horizontal power line flows in the east to west direction. What is the direction of magnetic field at a point directly below it ?
- (1) South to North
 - (2) West to East
 - (3) North to South
 - (4) None of these
18. The magnification produced by a spherical mirror is
- (1) The ratio of the height of the object to the height of the image.
 - (2) The ratio of the height of the image to the height of the object.
 - (3) The ratio of the height of the spherical mirror to the height of the object.
 - (4) None of these

19.

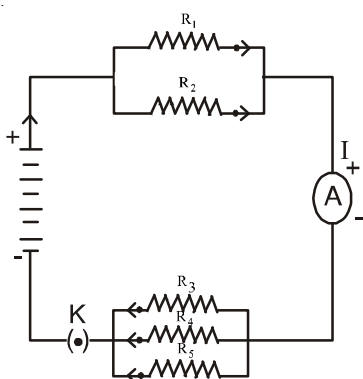

If in the above figure $R_1=10\Omega$, $R_2=40\Omega$, $R_3=30\Omega$, $R_4=20\Omega$, $R_5=60\Omega$ and a 12V battery is connected to the arrangement, the total resistance in the circuit will be

- (1) 18 Ω
 - (2) 20 Ω
 - (3) 22 Ω
 - (4) None of these
20. Diamond and graphite are the allotropes of carbon. They have the same chemical properties but vary in their physical properties. This is because
- (1) In diamond each carbon atom is bonded to four other carbon atoms forming a rigid three dimensional structure where as in graphite each carbon atom is bonded to three other carbon atoms in the same plane giving a hexagonal array.
 - (2) In diamond each carbon atom is bonded to three other

carbon atoms in the same plane giving a hexagonal array where as in graphite each carbon atom is bonded to four other carbon atoms forming rigid three dimensional structure.

- (3) In diamond, the pure carbon atoms are subjected to very high pressure and temperature where as graphite is made smooth and slippery.
 - (4) None of these
21. Which of the following regarding bases is correct?
- (1) An alkali is a base that dissolves in water.
 - (2) All bases do not dissolve in water.
 - (3) Both 1 and 2.
 - (4) None of these
22. Which of the following correctly balances the equation ?
- $$x \text{Pb(NO}_3)_2 \xrightarrow{\text{Heat}} y \text{PbO} + z \text{NO}_2 + \text{O}_2$$
- The x, y, z in the above reactions are
- (1) 2, 4, 2
 - (2) 2, 2, 4
 - (3) 4, 2, 4
 - (4) None of these
23. The speed of light is
- (1) Higher in an optically rarer medium than a denser medium.
 - (2) Lower in an optically rarer medium than a denser medium
 - (3) Same both in an optically rarer and denser medium.
 - (4) None of these
24. In Newland's 'Law of Octaves', which two elements in the periodic table have the same properties?
- (1) Potassium and Caesium
 - (2) Strontium and Barium
 - (3) Lithium and Sodium
 - (4) None of these
25. In the reactivity series, which of the following metal is the most reactive ?
- (1) Iron
 - (2) Sodium
 - (3) Copper
 - (4) None of these
26. Bleaching powder when mixed with water produces which gas?
- (1) Hydrogen
 - (2) Carbondioxide
 - (3) Chlorine
 - (4) None of these
27. Which formula gives the relationship between the object-distance (u), image-distance (v) and the focal length (f) of a spherical lens.
- (1) $\frac{1}{v} - \frac{1}{u} = \frac{1}{f}$
 - (2) $\frac{1}{u} - \frac{1}{v} = \frac{1}{f}$
 - (3) $\frac{1}{v} + \frac{1}{u} = \frac{1}{f}$
 - (4) None of these
28. The sun is visible to us about 2 minutes before the actual sunrise and about 2 minutes after the actual sunset because of
- (1) Dispersion
 - (2) Scattering of light
 - (3) Atmospheric refraction
 - (4) None of these

29.



An electron enters a magnetic field at right angles to it as shown in the above figure. The direction of force acting on the electron will be

- (1) to the right (2) into the paper
(3) to the left (4) None of these

30. In the modern periodic table the atomic radius decreases in moving from left to right along a period. This is due to
- (1) an increase in nuclear charge which tends to pull the electrons closer to the nucleus and reduces the size of the atom.
(2) a decrease in nuclear charge which tends to push the electrons towards nucleus and increases the size of the atom.
(3) an increase in nuclear charge which tends to pull the electrons closer to the nucleus and increases the size of the atom.
(4) None of these

SECTION-C : MATHEMATICS

31. Find the multiplicative inverse of $3+2i$:
- (1) $\frac{3}{13} - \frac{2}{13}i$ (2) $\frac{2}{13} - \frac{3}{13}i$
(3) $\frac{2}{13}i$ (4) None of these
32. According to De-Morgan's laws if A and B are any two sets then
- (1) $(A \cup B)' = A' \cup B'$ (2) $(A \cup B)' = A' \cap B'$
(3) $(A \cup B)' = A' B'$ (4) None of these
33. For which values of a, the system of equations $4x + ay + 5 = 0$
 $2x + 3y + 7 = 0$ has exactly one solution?
- (1) All values of a
(2) All values of a except 6
(3) All values of a except 6, 7
(4) None of these
34. A fraction becomes $\frac{4}{5}$ if 1 is added to each of the numerator and the denominator. However, if we subtract 5 from each, the fraction becomes $\frac{1}{2}$, find the fraction.
- (1) $\frac{9}{2}$ (2) $\frac{9}{7}$
(3) $\frac{7}{9}$ (4) None of these
35. Find the slope of a line whose inclination with x-axis is 135° ,
- (1) 1 (2) $\frac{1}{2}$
(3) -1 (4) None of these
36. $A = \begin{pmatrix} 2 & 3 \\ 4 & 5 \end{pmatrix}$, $B = \begin{pmatrix} 1 & 2 \\ 3 & 4 \end{pmatrix}$ find $A + 2B^T$

- (1) $\begin{pmatrix} 4 & 9 \\ 8 & 13 \end{pmatrix}$ (2) $\begin{pmatrix} 9 & 4 \\ 8 & 13 \end{pmatrix}$
(3) $\begin{pmatrix} 13 & 9 \\ 8 & 4 \end{pmatrix}$ (4) None of these

37. Which term of the series 5, 8, 11, 14, is 320 ?
- (1) 106^{th} (2) 104^{th}
(3) 105^{th} (4) None of these
38. If the fourth term of a G.P. is 5, the product of its first seven terms will be
- (1) 4^5 (2) 5^7
(3) 5^6 (4) None of these
39. Find the radius of a circular field if its area is 1386 cm^2 ?
- (1) 21 cm (2) 22 cm
(3) 24 cm (4) None of these
40. The mean of the values x_1, x_2, \dots, x_n of a variable x is denoted by \bar{x} and is given by

$$\bar{x} = \frac{x_1 + x_2 + \dots + x_n}{n} \text{ which is equal to}$$

- (1) $\sum_{i=1}^n x_i$ (2) $\frac{1}{n} \sum_{i=1}^n x_i$
(3) $\frac{1}{n} x_i$ (4) None of these

SECTION-C : BIOLOGY

31. In organisms glucose a 6 carbon molecule is broken down into a 3 carbon molecule called pyruvate. This process takes place in the
- (1) Cytoplasm (2) Nucleus
(3) Chloroplast (4) None of these
32. If the pollen is transferred from the stamen to the stigma of one flower to another flower it is known as
- (1) Self-pollination (2) Cross-pollination
(3) Germination (4) None of these
33. In Rhizopus which structure contains cells or spores that can eventually develop into new Rhizopus individuals?
- (1) Buds (2) Sporangia
(3) Hyphae (4) None of these
34. The wings of bats are skin folds stretched mainly between the elongated fingers where as the wings of birds are a feathery covering all along the arm. These are examples for
- (1) Homologous Organs (2) Both 1 and 3
(3) Analogous Organs (4) None of these
35. Which of the following statements are true?
- (1) The nervous system gets information from our sense organs and acts through our muscles.
(2) The nervous system uses electrical impulses to transmit messages.

- (3) Both 1 and 2.
 (4) None of these.
36. Sexually reproducing individuals have two copies of genes for the same trait. If the copies are not identical, the trait that gets expressed is called
 (1) Dominant trait (2) Recessive trait
 (3) Acquired (4) None of these
37. Drunken people find it difficult to maintain the posture and balance of the body. Which part of the brain will be affected by alcohol?
 (1) Cerebellum (2) Medulla
 (3) Cerebrum (4) None of these
38. ATP means
 (1) Adenine triphosphate
 (2) Adenosine triphosphate
 (3) Adrenaline tetrapyruvate
 (4) None of these
39. In plants when the stomata are open during the day, which of the following becomes the major driving force in the movement of water in the xylem?
 (1) Transpiration (2) Root pressure
 (3) Evaporation (4) None of these
40. The finger-like projection called 'villi' which is present in the inner lining of the small intestine has the advantage of
 (1) Supplying the unabsorbed food into the large intestine where absorption of water from the food takes place
 (2) increasing the surface area of absorption of the digested food
 (3) digesting the food by the secretion of digestive enzymes.
 (4) None of these.

EtG INTERACTIVE SECTION

41. In plants the ovary grows rapidly and ripens to form a fruit. Meanwhile the petals, sepals, stamens, style and stigma may shrivel and fall off. If a fruit develops from any part other than the ovary it is a false fruit. Which of the following is a 'false fruit' ?
 (1) Banana (2) Apple
 (3) Pine apple (4) None of these

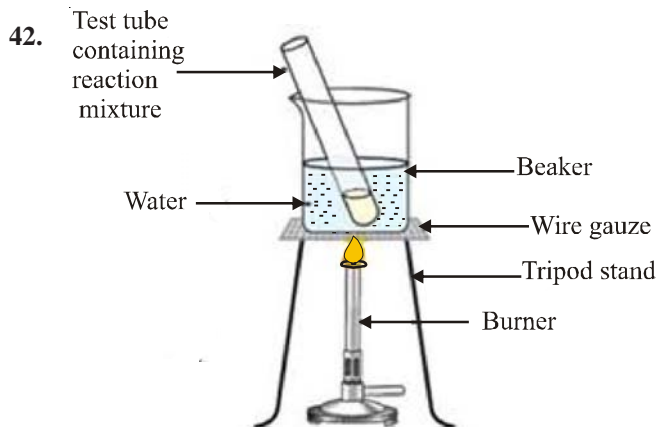

Take 1 ml ethanol and 1 ml glacial acetic acid along with a few

drops of concentrated sulphuric acid in a test tube. Warm in a water-bath for at least 5 minutes. Pour into a beaker containing 50 ml of water and smell the resulting mixture. What will be the product formed in this Fischer esterification reaction ?

- (1) Ethyl ethanoate (2) Ethene
 (3) Sodium acetate (4) None of these
43. In the above question the reaction between ethanol and glacial acetic acid can be represented as
- (1) $(\text{CH}_3\text{CO})_2\text{O} + \text{CH}_3\text{CH}_2\text{OH} \xrightleftharpoons{\text{Con H}_2\text{SO}_4} \text{CH}_2\text{COHCH}_2\text{CH}_3 + \text{CH}_3\text{COOH}$
- (2) $\text{CH}_3\text{COCl} + \text{CH}_3\text{CH}_2\text{OH} \rightarrow \text{CH}_3\text{COOCH}_2\text{CH}_3 + \text{HCl}$
- (3) $\text{CH}_3\text{COOH} + \text{CH}_3\text{CH}_2\text{OH} \xrightleftharpoons{\text{Con H}_2\text{SO}_4} \text{CH}_3\text{COOCH}_2\text{CH}_3 + \text{H}_2\text{O}$
- (4) None of these

44.

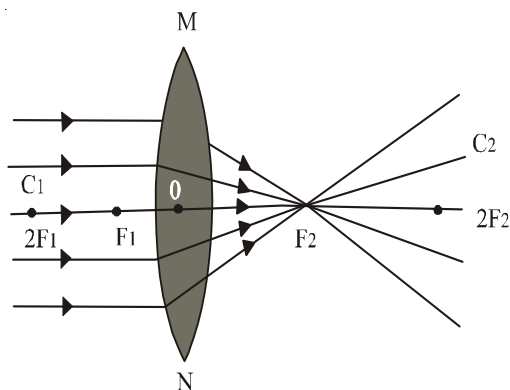

Hold a convex lens in your hand and direct it towards the sun. Focus the light from the sun on a sheet of paper. Obtain a sharp bright image of the sun. Hold the paper and the lens in the same position for a while. What happens to the paper ? What is the reason for it?

- (1) The paper may catch fire after a while. The parallel rays of light from the sun was converted by the lens at the sharp bright spot formed on the paper. The concentration of the sunlight at a point generated heat and this caused the paper to burn.
- (2) The paper may turn hot. The parallel rays of the sun was concentrated at the bright spot of the paper generating heat.
- (3) The paper may catch fire after a while. The parallel rays of light from the sun after refraction from the lens are appearing to diverge from a point on the principal axis. This caused the paper to burn.
- (4) None of these.

45.

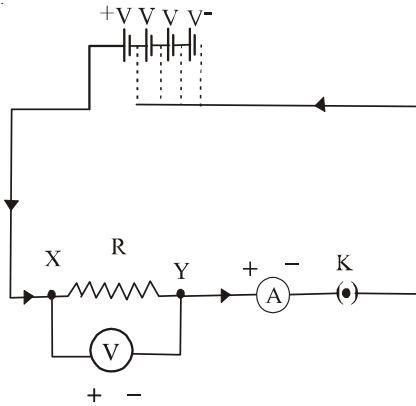

The above circuit consists of a nichrome wire XY of length 0.5m, an ammeter, a voltmeter and four cells of 1.5V each. First use only one cell as the source in the circuit. Note the reading in the ammeter A, for the current and reading of the voltmeter V for the potential difference across the nichrome wire. Next connect two, three and four cells in the circuit and note the respective readings separately. Plot a graph between V and A. Which of the following graph is correct ?

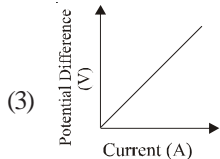
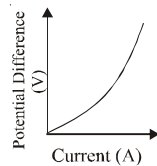
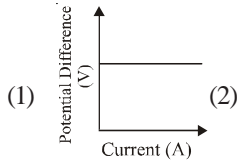

(4) None of these

46. Take a small aluminium rod AB. Using two connecting wires suspend it horizontally from a stand. Place a strong horse-shoe magnet in such a way that the rod lies between the two poles with the magnetic field directed

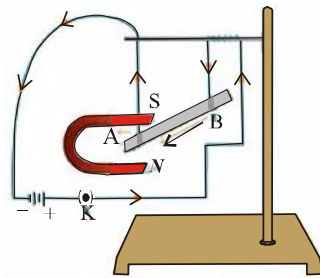

upwards. For this put the north pole of the magnet vertically below and south pole vertically above the aluminium rod. Connect the aluminium rod in series with a battery, a key and a rheostat. Pass a current from end B to end A. It is observed that the rod is displaced towards the left and displaced towards the right by reversing the direction of current.

The displacement of the rod suggests that

- (1) A force is exerted on the magnet when the electric current is passed.
- (2) A force is exerted on the current carrying aluminium rod when it is placed in a magnetic field.
- (3) Both 1 and 2.
- (4) None of these.

47. Detergents are used to make shampoos and products for cleaning clothes as they remain effective in hard water. This is because

- (1) Detergents are calcium and magnesium salts of short chain carboxylic acids. They react with the calcium and magnesium ions in water making them soluble.
- (2) Detergents are ammonium or sulphonate salts of long chain carboxylic acids. The charged ends of these compounds do not form insoluble precipitates with the calcium and magnesium ions in hard water.
- (3) Detergents are helpful in forming foam very easily in hard water.
- (4) None of these.

48. In the given food chain, which of the following comes at the second trophic level?

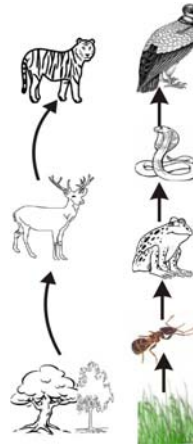

- (1) Deer
- (2) Frog
- (3) Snake
- (4) None of these

49. In the above question, what will be the average value for the amount of organic matter that is present at each step and reaches the next level of consumers?

- (1) 30%
- (2) 20%
- (3) 10%
- (4) None of these

50. Take 1g solid NaCl in a clean and dry test tube. Add some Concentrated H_2SO_4 to the test tube. Test the gas evolving from the delivery tube with dry and wet blue litmus paper. Which is the gas evolved in the above experiment ?

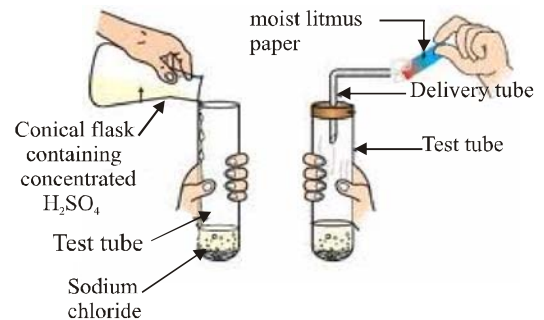

- (1) HCl
- (2) SO_2
- (3) O_2
- (4) None of these



END OF THE EXAM