



**EDUHEAL
FOUNDATION**

**CLASS
7**

**LEVEL - 1
Set A1**

EHF OLYMPIADS

- 4000 schools • 6 lakh students
- 11 olympiads • Global reach



EHF

**NATIONAL INTERACTIVE
SCIENCE OLYMPIAD™**

Name :

Roll No :

Class :

School :



art and Sports clinic contest

**NATIONAL
BIOTECHNOLOGY
OLYMPIAD**



**NATIONAL
INTERACTIVE
MATHS
OLYMPIAD**



**NATIONAL
INTERACTIVE
SCIENCE
OLYMPIAD**



**INTERNATIONAL
CYBER
OLYMPIAD**



**INTERNATIONAL
ENGLISH
OLYMPIAD**



**INTERNATIONAL
GENERAL KNOWLEDGE
OLYMPIAD**



Sponsored By:
BSE
INVESTORS' PROTECTION FUND

Business & international finance olympiad (BIFO)



NATIONAL IIT-NEET OLYMPIAD (NINO)

Go Online

Download



EHF Olympia

Mobile App & Win Prizes



Level - 1 : All Level-1 successful* participants will get certificate, aptitude report and school toppers will be eligible for school hero medals.

Level - 2 : School toppers* will be selected for level-2-National level - online computer based interactive test held at exam centres all over India. Winner will get merit certificate, medals, laptop, scholarship and other prizes.

Level - 3 : Middle and Senior Class Toppers will qualify# for level-3-International level-where you will compete with students globally. Get selected for EHF's Google Science Fair Online Training Camp. Represent India & win laurels. Guidance by top scientists.

Google

SCIENCE FAIR

*# See prospectus/website for details

WEBSITE : WWW.EDUHEALFOUNDATION.ORG

E-MAIL : INFO@EDUHEALFOUNDATION.ORG

ROUGH WORK





Instructions for the Candidate

1. You are allowed additional 10 minutes to fill the required details in the RESPONSE SHEET (OMR).
2. The question paper is made as per syllabus guidelines & pattern given in the information Booklet. The Question Paper for Classes 1 to 6 contains 40 Questions each to be answered in 60 minutes. The Question paper for classes 7 to 12 contains 60 Questions each to be answered in 60 minutes. All questions are compulsory. Further instructions are given in the instruction letter to the teacher.
3. Use the response sheet to mark your responses by darkening the required circle. The response sheet has to be returned to the foundation, duly filled in. **THE STUDENT CAN RETAIN THE QUESTION PAPER.**

GENERAL IQ

- Stomata are surrounded by
 - leaves
 - guard cells
 - carbohydrates
 - chloroplasts
- The salivary glands secrete-
 - pepsin
 - trypsin
 - bile juice
 - ptyalin
- Which type of wool is common in Tibet and Ladakh?
 - Pashmina wool
 - Sheep wool
 - Angora wool
 - None of these
- The capacity to do work is called-
 - Force.
 - Velocity
 - Energy
 - Power
- Substances which are bitter in taste, feel soapy on touching are known as
 - acids
 - bases
 - indicators
 - none of these
- Dry Ice (solid carbon dioxide — CO_2) is sublimed at room temperature:
 - Physical Change
 - Chemical Change
 - Can't say
 - None of these
- Climate of the north-eastern region is normally
 - wet
 - dry
 - moderate
 - none of these
- Look at the diagram and answer:

What will happen to the balloon if it is immersed in hot water?

 - 
 - 
 - 
 - none of these
- Which soil horizon contains humus?
 - A-horizon(top)
 - B-horizon(middle)
 - C-horizon(lower)
 - None of these
- Which of the following organism can do anaerobic respiration?
 - Yeast
 - Amoeba
 - Leech
 - None of these

GENERAL SCIENCE

11. Meher sliced a plant's stem into various sections and placed them under a microscope. He noticed that each of the sections had identical cell formations, which created tube-like structures in the stem.

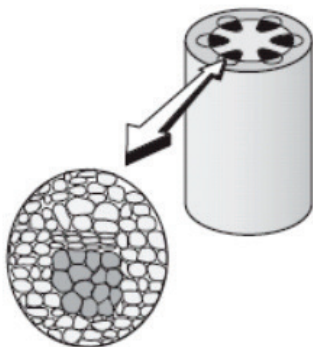

A main function of the stem is to

- (1) absorb minerals from the soil.
 - (2) transport food and water.
 - (3) protect against diseases.
 - (4) capture sunlight for photosynthesis.
12. Which is the first thing that would happen if a plant could **NOT** obtain carbon dioxide?
- (1) It would not be able to reproduce.
 - (2) It would not be able to make food.
 - (3) It would not be able to get rid of waste.
 - (4) It would not be able to absorb minerals.
13. Koustavi wanted to determine if certain seeds require sunlight to germinate. She placed one seed in a moist paper towel in the sunlight and another seed in an equally moistened paper towel in a dark closet. The seed in the sunlight germinated but the one in the closet did not. Koustavi reported to the class that this type of seed needs sunlight in order to germinate.

Given this information, which statement would **best** describe an improvement in Koustavi experiment that would strengthen her claim?

- (1) Use many seeds to conduct the experiment.
 - (2) Start the samples on different days.
 - (3) Use different amounts of water.
 - (4) Place the seeds in new locations.
14. Use the illustration and your knowledge of science to answer the question.

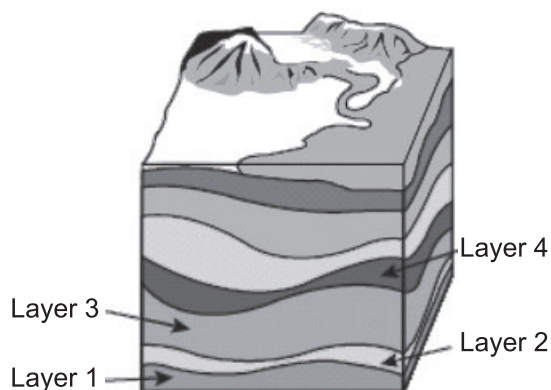

Which layer of sedimentary rock is the oldest?

- (1) Layer 4
 - (2) Layer 3
 - (3) Layer 2
 - (4) Layer 1
15. Which motion describes molecules in a solid at extremely low temperatures?
- (1) bumping together with some room to move
 - (2) vibrating while closely packed together
 - (3) moving freely and randomly in a space
 - (4) sliding around one another and colliding

16. Meera dissected a flowering plant and looked at the stem, roots, leaves, and flower using a microscope. After her observations, Meera should conclude that all flowering plant structures

- (1) are not living.
- (2) have the same function.
- (3) have cells.
- (4) are green.

17. The following test design was developed by researchers:

Sleep Study

- 1. Select a volunteer to participate in the study.
- 2. Ask the volunteer to read a short story just before going to sleep.
- 3. Give the volunteer a multiple-choice test on the short story the following day.
- 4. Record the test results.

Which of the following describes the **greatest** flaw with the experimental design?

- (1) the test results were recorded
- (2) the volunteer went to sleep
- (3) the study was done overnight
- (4) only one volunteer participated

18. Some insects consume nectar from flowering plants and help the plant by spreading pollen. Which type of relationship between insects and plants does this demonstrate?

- (1) parasitic
- (2) competitive
- (3) predator-prey
- (4) mutually beneficial

19. Use the food chain and your knowledge of science to answer the question.

Chilka Lake Food Chain

plankton → mosquito larvae
→ sculpin (a small fish) → lake trout

Which of the following would be the **most likely** result of a reduction in the lake trout population?

- (1) Sculpin and mosquito larvae populations would both increase.
- (2) Sculpin and mosquito larvae populations would both decrease.
- (3) The plankton population would decrease.
- (4) The sculpin population would increase.

20. Which action would have the **greatest** impact on reducing river pollution in a farm area?

- (1) planting crops that absorb less water
- (2) plowing land earlier in the year
- (3) controlling the use of fertilizer
- (4) increasing irrigation of crops

21. Engineers have recently developed alternative fuels such as ethanol to power vehicles. Ethanol is a fuel that is made from corn or other crops including wheat, barley, and potatoes. E85 is a mixture of 85% ethanol and 15% gasoline.

The greatest environmental advantage to using E85 would be that

- (1) It has gasoline mixed in it.
- (2) It is used to power vehicles.
- (3) It is made up mostly of renewable resources.
- (4) It is made from crops that require powerful fertilizers.

22. Many lizards that live in Thar, Rajasthan are unable to live in Ladakh. Which statement **best** explains why Thar, Rajasthan lizards have difficulty surviving in Ladakh?
- (1) They have the ability to live both on land and in the water.
 - (2) They are unable to live where temperatures are lower than -1.1°C .
 - (3) They have the ability to live where temperatures are above 37.8°C .
 - (4) They are unable to live where there is no water.
23. Which statement **best** describes organisms in a food web?
- (1) Producers acquire energy directly from the consumers.
 - (2) Consumers acquire energy indirectly from the Sun.
 - (3) Decomposers acquire energy directly from the Sun.
 - (4) Producers acquire energy indirectly from the decomposers.
24. When a solid substance is heated, individual molecules
- (1) move faster.
 - (2) move slower.
 - (3) break apart into atoms.
 - (4) do not change speed or direction.
25. Fog would **most likely** occur when
- (1) cool rain falls on warmer ground.
 - (2) air pressure increases and water vapor decreases.
 - (3) relative humidity decreases and dew point decreases.
 - (4) moist air passes over cooler ground causing condensation.
26. Which characteristic of Earth is **most** responsible for our seasons?
- (1) Earth's gravitational pull on the moon
 - (2) Earth's rotation
 - (3) Earth's mass
 - (4) Earth's tilt on its axis
27. On a hot day, a glass containing ice water slowly collects liquid on the outside of the glass. Which statement **best** explains where this liquid come from?
- (1) Air molecules outside of the glass turned to liquid on the outside surface of the glass.
 - (2) Water from the inside of the glass seeped to the outside of the glass.
 - (3) Water vapor from the air outside of the glass condensed on the outside surface of the glass.
 - (4) Water from inside the glass and water from the air outside the glass combined on the outside of the glass.
28. During a scientific investigation, when should measurements be recorded?
- (1) when forming a hypothesis
 - (2) when designing an experiment
 - (3) when communicating results
 - (4) when gathering data

29. The diagram below shows exposed rock layers. Each rock layer contains a fossil of a different organism.

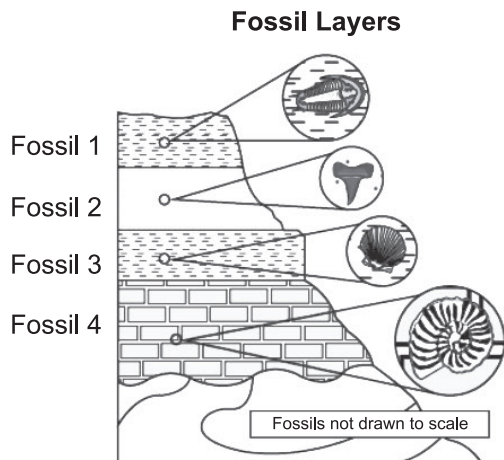

Which fossil **most likely** represents the oldest form of life?

- (1) Fossil 1 (2) Fossil 2
 (3) Fossil 3 (4) Fossil 4
30. Four students work in a group to learn how rocks are formed. The teacher gives each of them a blue crayon and a red crayon and tells them to follow the steps on the board, as shown below.

How Rocks are Formed

Step	Activity
1	Break up the red and blue crayons into tiny pieces.
2	Put the pieces in your hand and squeeze them together to form a red-and-blue-speckled slab.
3	Place the slab in a beaker, and place the beaker on a hot plate to melt the slab.
4	Place the beaker with the melted slab into a bucket of ice to cool it down.

Which step **best** represents how a sedimentary rock is formed?

- (1) Step 1 (2) Step 2
 (3) Step 3 (4) Step 4

31. Jay determined the mass of four rock samples. Then, he put each rock sample in a cup of vinegar for three days. The table below represents the data he collected during his investigation.

Rock Sample Data

Rock Sample	Mass of Rock Before Placed in Vinegar (g)	Mass of Rock After Placed in Vinegar (g)	Observations
1	10	10	no change
2	20	20	no change
3	15	10	some bubbles
4	15	5	many bubbles

Which statement is the **best** conclusion from the rock sample data?

- (1) Rocks 1 and 2 are the same type of rock.
 (2) Rock 4 is an igneous rock.
 (3) Rocks 3 and 4 are chemically changed.
 (4) Rocks 1, 2, 3, and 4 are the same type.
32. What is the **main** reason for clearly recording the procedures for an experiment?
- (1) so the experiment can be modified
 (2) so the experiment can be connected
 (3) so the experiment can be repeated
 (4) so the experiment can be summarized
33. A group of students predicts that folding an index card into a different shape will result in a chemical change. Which step of the scientific process is this?
- (1) experiment
 (2) observation
 (3) hypothesis
 (4) conclusion

34. Plants absorb light energy and store that energy in the form of

- (1) water. (2) carbon dioxide.
 (3) sugar. (4) oxygen.

35. Which process will produce igneous rocks?

- (1) deposition of sediments
 (2) volcanic action
 (3) earthquake activity
 (4) erosion of surface rocks

36. A chemical change could **best** be demonstrated by

- (1) burning a piece of paper.
 (2) folding a piece of paper.
 (3) cutting a piece of paper.
 (4) dropping a piece of paper.

37. Which is the most basic unit of matter?

- (1) compound (2) element
 (3) mixture (4) molecule

38. What is the main function of an individual muscle cell?

- (1) to grow and repair tissues
 (2) to relax and contract tissues
 (3) to support and protect organs
 (4) to transmit and receive impulses

39. Which diagram shows the relative positions of Earth, the Moon and the Sun during a lunar eclipse?

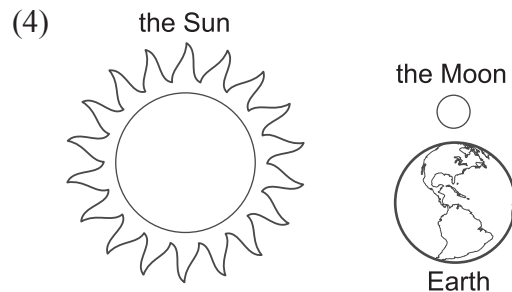
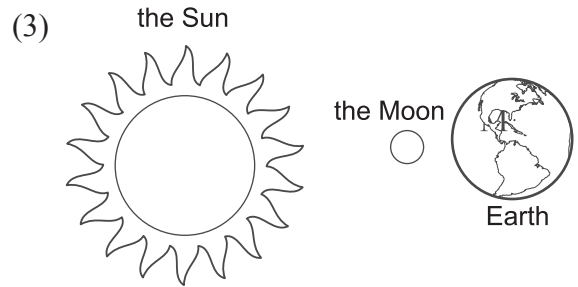
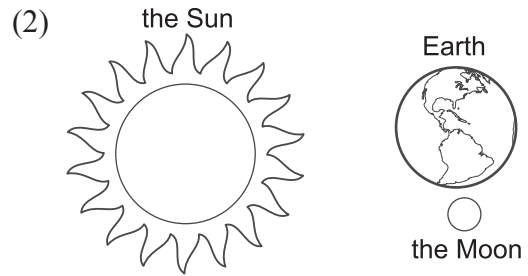
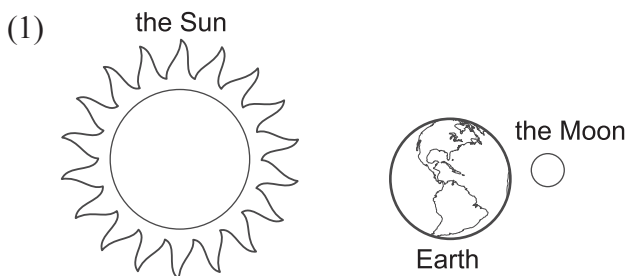

40. A company designed an electromagnetic tool that removes dents from metal plates. The dented metal is placed between two magnets. A current is then supplied to the electromagnets. The attraction between the two magnets forces the dented metal plate back into place. How can engineers test to see if their design is successful?

- (1) compare the cost of operating the tool to other dent removal tools
 (2) compare the shape of the treated metal with the original shape of the metal
 (3) compare the type of metal plates treated by the company to those of other companies
 (4) compare the energy requirements of two similar dent removal tools

INTERACTIVE SECTION

41. Which diagram best shows the position of Earth, the moon and the Sun when there is a new moon?

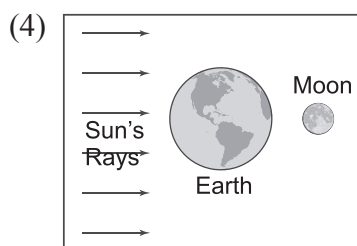
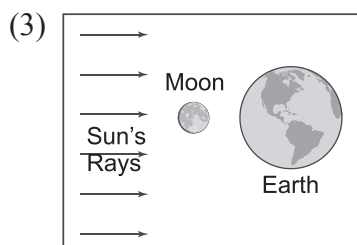
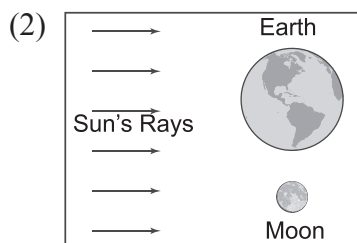
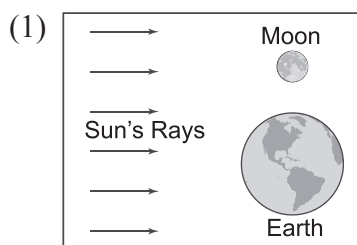

42. A diagram of a roller coaster moving to the top of a hill is shown.

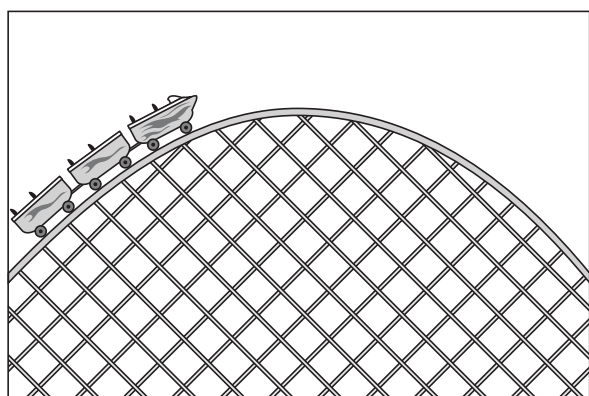

Which type of energy will be greatest at the top of the hill?

- (1) chemical potential energy
- (2) nuclear potential energy
- (3) elastic potential energy
- (4) gravitational potential energy

43. The table lists some characteristics of objects in our solar system.

Objects in Our Solar System

Object	Location	Diameter
Asteroid	Orbits the Sun	Up to 1,000 km
Moon	Orbits a planet	Up to 5,268 km
Halley's Comet	Orbits the Sun	8 km
Planet in solar system	Orbits the Sun	4,880 – 142,800 km

Scientists observe an object with a diameter of 950 km in an orbit around the sun. Scientists will most likely identify it as which type of object?

- (1) Asteroid
- (2) Moon
- (3) Comet
- (4) Planet

44. Which is the best example of an assistive bioengineered product?

- (1) a rosebush that is bred to have roses of a particular color
- (2) a computer program that helps a paralyzed person control a wheelchair
- (3) a pesticide produced from the compounds of a plant
- (4) a bacterium that generates oil byproducts in the presence of sunlight

45. A grassland food web is shown below.

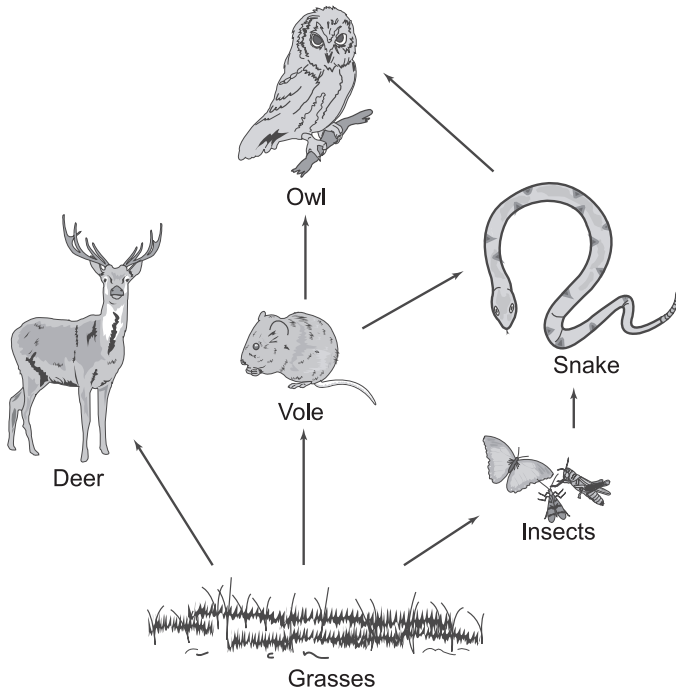

The owl most directly obtains energy from which organism?

- (1) Vole
- (2) Insects
- (3) Deer
- (4) Grasses

46. Which diagram best represents one day on Earth?

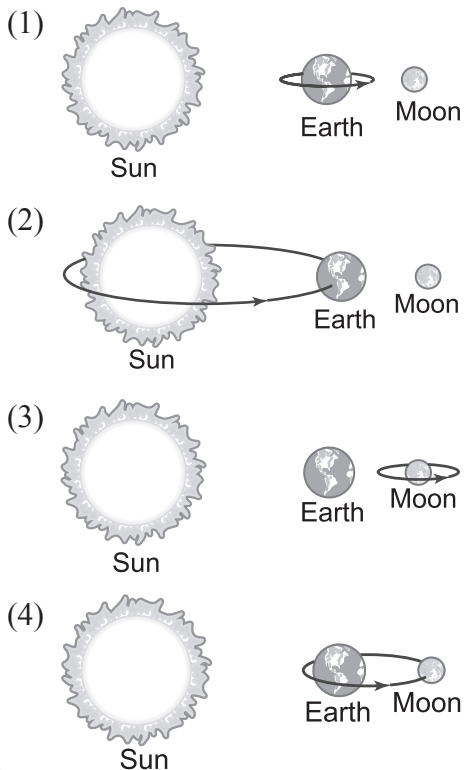

47. Which is the best example of chemical potential energy?

- (1) a book resting on a shelf
- (2) a stretched rubber band
- (3) a fuel tank containing gasoline
- (4) a pencil falling off a table

48. Cold ocean currents are most likely to be located at deeper ocean depths than warm water currents because

- (1) winds push the cold water down.
- (2) ocean tides force cold water downward.
- (3) cold water is more dense and sinks.
- (4) cold water has less salt to help it freeze and sink.

49. A Grassland food web is shown below.

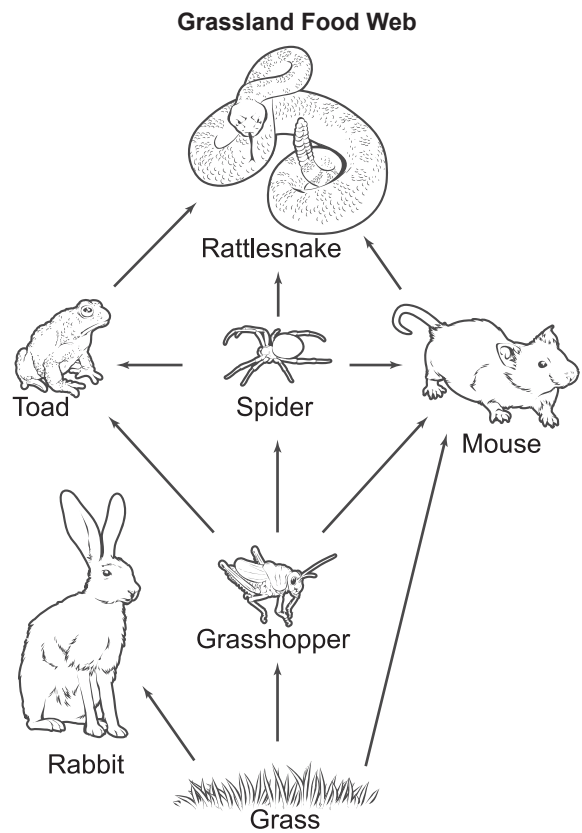

Which group of organisms is made up of only consumers?

- (1) Spider, Grass, Mouse
- (2) Toad, Grass, Rabbit
- (3) Grasshopper, Mouse, Grass
- (4) Rattlesnake, Grasshopper, Spider

50. Which most likely causes the movement of warm surface ocean currents?

- (1) Sunlight heats air forming strong winds that push currents.
- (2) Low and high tides create energy for current movement.
- (3) Shifting ocean plates force water toward the poles.
- (4) Warm waters help in the melting of icebergs and glaciers.

51. Each diagram shows a circuit. The number one represents a buzzer and the number two represents a clock. Which diagram most likely shows a circuit producing sound?

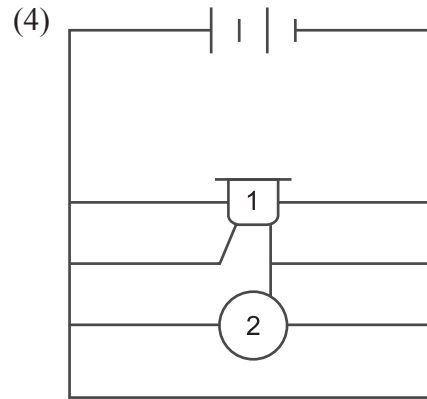
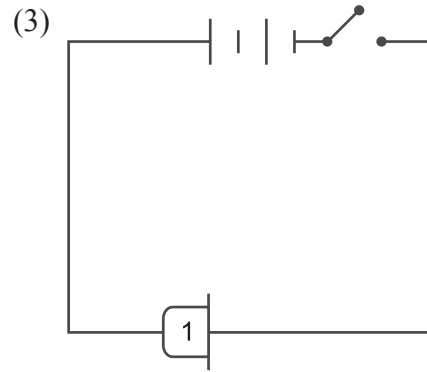
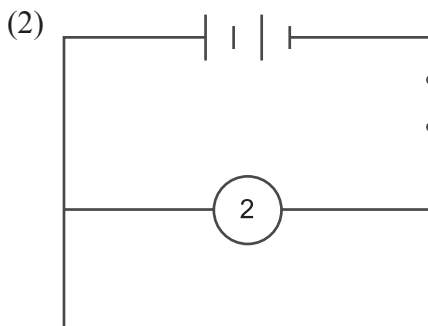
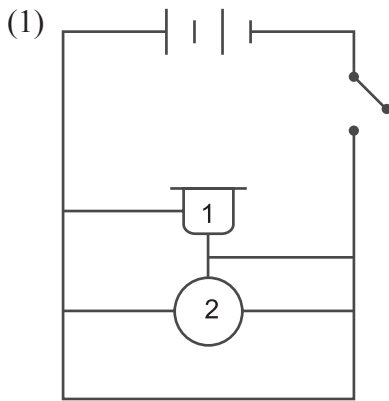

52. The drawing below shows a sea breeze.

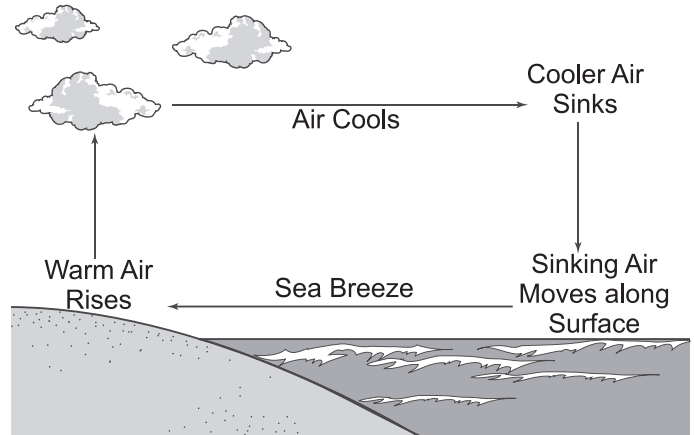

When is this type of wind pattern most likely to occur?

- (1) during the day when the land heats faster than the surface of the sea
- (2) during the night when the surface of the sea cools faster than the land
- (3) during the day when the sea is as warm as the land
- (4) during the night when the air above land is warmer than the air above the sea

53. Venus appears very bright in the night sky because it
- (1) has a gravitational field.
 - (2) is the largest planet.
 - (3) is the closest planet to Earth.
 - (4) has a high surface temperature
54. When turning on a flashlight, a chemical reaction in the battery produces electricity that lights a bulb. According to the Law of Conservation of Energy, the energy exchanged between the battery and the flashlight
- (1) is created.
 - (2) loses matter.
 - (3) is destroyed.
 - (4) changes forms.
55. What happens to some of the energy in a green plant when it is consumed by a deer?
- (1) It is destroyed.
 - (2) It doubles in size.
 - (3) It helps maintain body heat.
 - (4) It is converted into a pure element.
56. Which type of energy is converted when fireworks release heat, light, and sound?
- (1) kinetic energy
 - (2) elastic potential energy
 - (3) chemical potential energy
 - (4) electromagnetic energy
57. A student sees the moon and says, "The moon looks larger than the stars." Which best explains why the student makes this observation?
- (1) The moon is reflecting light from the Sun.
 - (2) The moon is closer to Earth than the stars.
 - (3) The moon is much larger than the stars.
 - (4) The moon is much larger than Earth.
58. The barometer reading on a local weather forecast was 29.80 mm Hg and falling. What type of weather conditions are most likely about to occur?
- (1) clear and cool
 - (2) clear and warm
 - (3) fair skies
 - (4) cloudy skies
59. The soil in a deciduous forest typically contains many nutrients and supports the growth of various plants. Which statement explains why the soil is so nutrient rich?
- (1) The daily rainfall adds minerals to the soil.
 - (2) The temperature of the soil is perfect for plants to grow.
 - (3) The amount of sunlight the soil gets is perfect for plants.
 - (4) The soil is high in organic matter from decomposers.
60. Ocean currents bring deep, nutrient-rich water to the surface. What causes these currents to move upward?
- (1) Warm rainwater mixes with surface water, pushing deep water upward.
 - (2) Cold surface water from the poles sinks, pushing deep water upward.
 - (3) Wind currents cause surface water to sink, pushing deep water upward.
 - (4) Surface runoff from rivers causes warm water to sink, pushing deep water upward.



END OF THE EXAM